

FEATURES

The unique swirl chamber is the heart of Delavan's Mini-SDX nozzle design. The single inlet spiral configuration produces a natural, free vortex pattern. Friction is minimised, permitting 10-20% lower operating pressure than conventional slotted distributor nozzles. This lengthens both pump and nozzle life.

SPRAY CHARACTERISTICS

- The Mini-SDX nozzle produces a hollow cone spray pattern with relatively uniform droplet size and particle distribution.
- Nominal spray angle is 70°-75°.
- Flow rates on water at 69 Bar.G. range from as low as 24.2 litres/hour to as high as 208 litres/hour, depending on nozzle size.

CONSTRUCTION AND MATERIALS

- Five part construction (see part and material list below).
- The orifice disc, a pressed fit insert, is recessed to protect against damage if dropped or hit.
- Wrench tighten only when replacing orifice disc by pressing into nozzle body with assembly tool, otherwise no wrench tightening should be done during assembly. Wrench tightening may result in fracture of the swirl chamber.
- The patented single inlet swirl chamber minimises plugging and maximises particle uniformity.
- The Viton O-ring seal allows assembly and disassembly without tools.
- Only assembly tool (P/N 36386) is needed for changing the pressed fit orifice disc.

ORDER EXAMPLE

When ordering specify the following:

- 1) Assembly part number from capacity chart
- or 2) Part numbers of individual items.

Max. Design Pressure: 350 Bar.G.
Max. Design Temperature: 150°C.

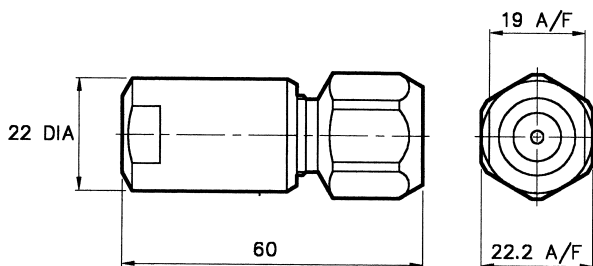

UNIQUE SWIRL CHAMBER

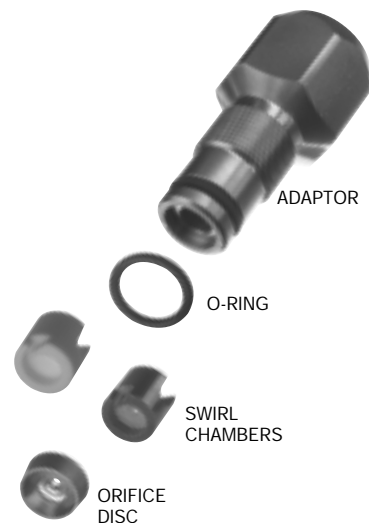

MATERIALS AND WEIGHTS

DESCRIPTION	PART NO.	MATERIAL	WEIGHT (g)
Orifice Disc	902-XX [*]	Tungsten Carbide	8,5
Nozzle Body	32932	303 SS	62,4
Swirl Chamber	32933-X [*]	Ceramic	7,1
Swirl Chamber	50791-X [*]	Tungsten Carbide	9,9
O-Ring Seal	31352-013	Viton	2,3
1/4" NPTF Adaptor	32931-1	303 SS	85,0
3/8" NPTF Adaptor	32931-2	303 SS	71,0

* Refer to capacity chart for dash number.
NOTE: - 50791-1 is equivalent to 32933-1.

SEAL KIT (24 SEALS)

PART NO.	DESCRIPTION	MATERIAL
49109	Seal Kit	Viton

Contact our Helpline for any special requirements:
Tel: +44 (0) 151 424 6821
Fax: +44 (0) 151 495 1043
e-mail: sales@delavan.co.uk
Web: www.delavan.co.uk

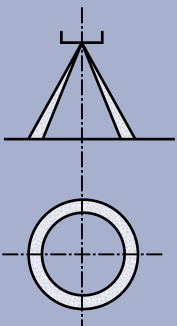

CAPACITY CHART

ASSEMBLY PART NUMBER	ADAPTOR	INLET THREAD (NPTF)	SWIRL CHAMBER	ORIFICE DISC	FLOW RATE IN LITRES/HOUR AT BAR.G.						APPROX. WEIGHT (g)
					34,5	69	138	207	276	345	
32936-47 32936-48	32931-1 32931-2	1/4 3/8	32933-4	902-18	17,4	24,2	34	42	48,4	53,7	133 119
32936-49 32936-50	32931-1 32931-2	1/4 3/8	32933-4	902-20	18,5	25,7	36,3	44,6	51,5	57,5	133 119
32936-51 32936-52	32931-1 32931-2	1/4 3/8	32933-4	902-22	20,4	28,4	40,1	49,2	56,8	63,6	133 119
32936-53 32936-54	32931-1 32931-2	1/4 3/8	32933-4	902-24	23,5	32,5	46,2	56,4	65,1	72,6	133 119
32936-55 32936-56	32931-1 32931-2	1/4 3/8	32933-4	902-27	26,9	37,8	53,3	65,5	75,7	84,7	133 119
32936-1 32936-2	32931-1 32931-2	1/4 3/8	32933-1	902-22	29,5	41,6	59,0	72,2	83,2	93,1	133 119
32936-3 32936-4	32931-1 32931-2	1/4 3/8	32933-1	902-24	34	47,3	67	82	94,6	105,9	133 119
32936-5 32936-6	32931-1 32931-2	1/4 3/8	32933-1	902-27	38,6	54,9	77,6	95	109,8	122,6	133 119
32936-7 32936-8	32931-1 32931-2	1/4 3/8	32933-1	902-30	44,3	62,4	88,2	108,2	124,8	140,1	133 119
32936-9 32936-10	32931-1 32931-2	1/4 3/8	32933-2	902-30	53,3	75,7	107,1	130,9	151,3	169,1	133 119
32936-11 32936-12	32931-1 32931-2	1/4 3/8	32933-2	902-33	60,1	85,1	120,3	147,5	170,2	190,3	133 119
32936-13 32936-14	32931-1 32931-2	1/4 3/8	32933-2	902-36	67	94,6	133,9	163,8	189,2	211,5	133 119
32936-15 32936-16	32931-1 32931-2	1/4 3/8	32933-2	902-38	70,7	100,3	141,9	173,3	200,5	224,4	133 119
32936-17 32936-18	32931-1 32931-2	1/4 3/8	32933-2	902-40	77,6	109,7	155,1	189,9	219,4	245,1	133 119
32936-19 32936-20	32931-1 32931-2	1/4 3/8	32933-2	902-42	80,2	113,5	160,8	196,7	227	253,5	133 119
32936-21 32936-22	32931-1 32931-2	1/4 3/8	32933-2	902-44	82,9	117,3	164,2	203,5	234,6	262,1	133 119
32936-23 32936-24	32931-1 32931-2	1/4 3/8	32933-2	902-46	87	123	174	213	245,9	275	133 119
32936-25 32936-26	32931-1 32931-2	1/4 3/8	32933-2	902-48	90,8	132,4	187,3	229,3	264,8	296,2	133 119
32936-27 32936-28	32931-1 32931-2	1/4 3/8	32933-2	902-50	97,6	138,1	195,2	239,1	276	308,7	133 119
32936-29 32936-30	32931-1 32931-2	1/4 3/8	32933-2	902-52	105,6	149,4	211,5	258,8	298,9	334,1	133 119
32936-31 32936-32	32931-1 32931-2	1/4 3/8	32933-2	902-54	109,7	155,1	219,4	268,6	310,2	346,9	133 119
32936-33 32936-34	32931-1 32931-2	1/4 3/8	32933-2	902-56	113,5	158,9	224,7	275,4	317,8	355,6	133 119
32936-37 32936-38	32931-1 32931-2	1/4 3/8	32933-3	902-50	117,3	169,5	239,5	293,6	339,0	378,3	133 119
32936-39 32936-40	32931-1 32931-2	1/4 3/8	32933-3	902-52	127,5	180,8	255,8	313,3	361,7	404,4	133 119
32936-41 32936-42	32931-1 32931-2	1/4 3/8	32933-3	902-54	135,1	191,1	270,1	331	382,1	427,1	133 119
32936-43 32936-44	32931-1 32931-2	1/4 3/8	32933-3	902-56	143,8	202,4	286,4	350,7	404,8	452,5	133 119
32936-45 32936-46	32931-1 32931-2	1/4 3/8	32933-3	902-58	147,2	208,1	294,3	360,6	416,2	465,3	133 119

All Spray Angles 70°-75°.

Contact our Helpline for
any special requirements:
Tel: +44 (0) 151 424 6821
Fax: +44 (0) 151 495 1043
e-mail: sales@delavan.co.uk
Web: www.delavan.co.uk

