

SPRAY CHARACTERISTICS

- Produces a wide, flat spray pattern with uniform distribution.
- Low impact spray with low atomization at lower pressures.
- 120° nominal spray angle or more depending on size.

CONSTRUCTION AND MATERIALS

- Simple deflector-type design producing spray at 75° spray angle from inlet orifice. Wide angle coverage at low pressures.
- Tips are interchangeable and replaceable.
- Available in Brass and Stainless Steel.
- Other materials available to special order.
- Nozzle will fit into standard nozzle bodies and cap.
- Thread sizes are Male BSPT and Female BSPT.

ORDER EXAMPLE

D 10 Stainless Steel = Tip Only.

3/8" Female D 20 Brass = Complete Assembly.

DIMENSIONS AND WEIGHTS

Assembly Type	Dimensions (mm)			Weight (g)
	A Hex	B	C Hex	
1/8" Female	20,8	50,0	18,0	74
1/4" Male	20,8	50,0	18,0	66
1/4" Female	20,8	50,0	18,0	72
3/8" Male	20,8	50,0	18,0	68
3/8" Female	20,8	50,0	20,8	74
Tip	14,7 dia.	15,9	12,4 dia.	10

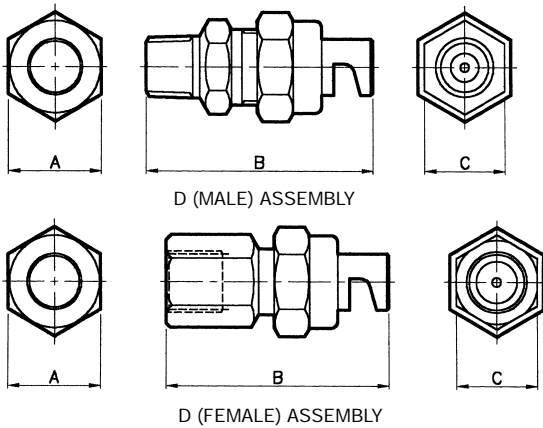

Maximum Recommended Pressure: 35 Bar.G.

CAPACITY CHART

NOZZLE NUMBER	Appox. Orifice Dia. (mm)	FLOW RATE IN LITRES/MIN AT Bar.G.							Spray Angle (°) At 1.5 Bar. G.
		0,5	0,7	1,0	1,5	2,0	3,0	4,0	
D 0.5	0,7	0,16	0,19	0,23	0,28	0,32	0,39	0,46	90
D 0,75	0,8	0,24	0,29	0,34	0,42	0,48	0,59	0,68	105
D 1	0,9	0,32	0,38	0,46	0,56	0,65	0,79	0,91	110
D 1.5	1,1	0,48	0,57	0,68	0,84	0,97	1,18	1,37	115
D 2	1,2	0,65	0,76	0,91	1,12	1,29	1,57	1,82	115
D 2,5	1,3	0,81	0,95	1,14	1,40	1,61	1,96	2,28	115
D 3	1,5	0,97	1,14	1,37	1,68	1,93	2,36	2,74	120
D 4	1,8	1,29	1,53	1,82	2,23	2,59	3,14	3,65	120
D 5	2,0	1,61	1,91	2,28	2,79	3,22	3,93	4,56	130
D 6	2,2	1,93	2,29	2,74	3,35	3,87	4,71	5,47	130
D 7,5	2,4	2,42	2,86	3,42	4,19	4,84	5,89	6,84	140
D 10	2,7	3,22	3,81	4,56	5,58	6,45	7,85	9,12	145
D 15	3,3	4,83	5,72	6,84	8,37	9,67	11,78	13,68	125
D 18	3,6	5,80	6,97	8,21	10,05	11,60	14,14	16,41	140
D 20	3,8	6,45	7,63	9,12	11,17	12,89	15,71	18,23	140
D 25	4,2	8,06	9,54	11,40	13,96	16,12	19,63	22,79	125
D 30	4,6	9,67	11,44	13,68	16,75	19,34	23,56	27,35	130



FLAT SPRAY

TYPED

Contact our Helpline for any special requirements:
Tel: +44 (0) 151 424 6821
Fax: +44 (0) 151 495 1043
e-mail: sales@delavan.co.uk
Web: www.delavan.co.uk

